

REV	ECN NO.	DISCRIPTION	CHEKED/DATE	APPD/DATE

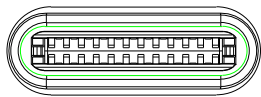
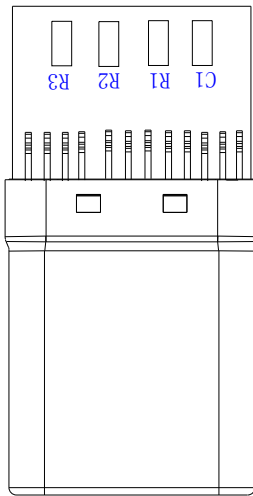
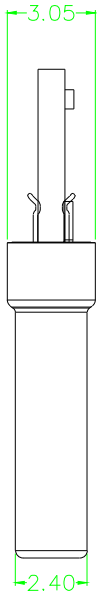
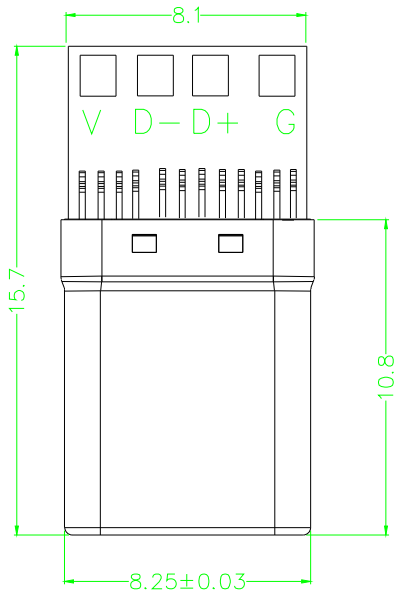
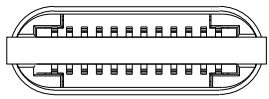

Notes:

1. Materials
 - a. Housing: LCP+30%GF, UL94 V-0;
 - b. Contact: High conductivity copper alloy, Gold Plating at mating area & solder tail, all over Nickel;
 - c. Shell: Stainless steel, all over Nickel;
 - d. Latch: Stainless steel, all over Nickel;
 - e. Mid-Plate: Stainless steel, all over Nickel;
2. Ratings
 - a. Voltage Rating: 15V AC;
 - b. Current Rating: 3A ;
 - c. Operating Temperature: -40° C ~ 85° C;
4. Electrical Requirement:
 - a. Contact Resistance: 30mΩ Max,
 - b. Dielectric Withstanding Voltage: 100V AC (RMS) for 1 minute;
 - c. Insulation Resistance: 500MΩ Min.
5. Mechanical Performance:
 - a. Insertion force: 5~20N. (from 1~10,000 Cycles);
 - b. Withdrawal force: 8~20N. (from 1~1,000 Cycles);
6~20N. (from 1,001~10,000 Cycles);
 - c. Durability life: 5,000 Cycles;

电阻56K ————— R2

电容 103 ————— C1

深圳市安锐微电子科技有限公司

未标注公差为±0.1

公差 (TOLERANCES)	模号 (Mold No)	比例 (Scale)	品名 (Produce Name)			
X	±0.15	1:1 (A4)	TYPE-C四芯拉伸倒角			
X.X	±0.10		料号 (Part No.)	ARTC-24CN02B-A008	单位 (Units)	MM
X.XX	±0.05	第三角投影	图名 (Draw Name)	成品图	页次 (Sheet)	1/1
X.XXX	±0.02		文件编号 (Draw No.)	WP-YMX058-P01	版次 (REV)	A0
Angle	±1.0°		核准 (APP'D)			